

C60-TUBE-100D

THIS DRAWING AND ALL DATA INCLUDED IS THE PROPERTY OF APPLIED SCIENTIFIC INSTRUMENTATION AND THE INFORMATION CONTAINED HEREIN IS FOR GENERAL PRESENTATION PURPOSES ONLY AND MAY CHANGE AT ANY TIME. CONTACT ASI OR A FACTORY REPRESENTATIVE FOR PROJECT SPECIFIC ENGINEERING.

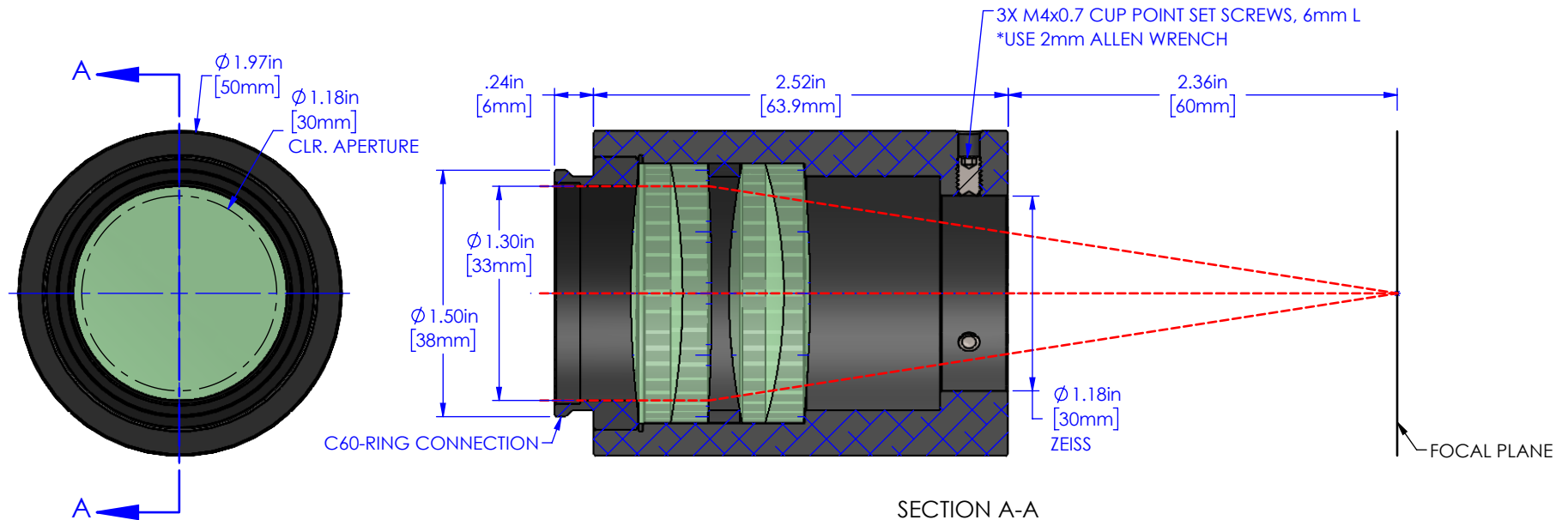

PROPRIETARY AND CONFIDENTIAL
THE INFORMATION CONTAINED IN THIS DRAWING IS THE SOLE PROPERTY OF APPLIED SCIENTIFIC INSTRUMENTATION. ANY REPRODUCTION IN PART OR AS A WHOLE WITHOUT THE WRITTEN PERMISSION OF APPLIED SCIENTIFIC INSTRUMENTATION IS PROHIBITED.

APPLIED SCIENTIFIC INSTRUMENTATION
29391 W ENID RD
EUGENE, OR 97402-9533
PHONE: (541)461-8181
FAX: (541)461-4018

UNLESS OTHERWISE SPECIFIED
DIMENSIONS ARE IN INCHES
.xx ± .01
.xxx ± .005
.xxxx ± .002
FRACTIONS ± 1/32
ANGLES ± 1°

DESCRIPTION

MODULAR INVERTED MICROSCOPE
MULTI-ELEMENT TUBE LENS ASSEMBLY, 100mm F.L.
MALE RING MOUNT IS PART OF THE TUBE.

DRAWN BY/DATE

M.ANTHONY 12/10/21

CHECKED BY/DATE

J.DANIELS / V.MARSO
12/10/21

SCALE

1:1

REV

-

MATERIAL

ALUM, ANODIZED BLK

DRAWING #

C60-TUBE-100D