

MS-2000 Flat Top XYZ Automated Stage

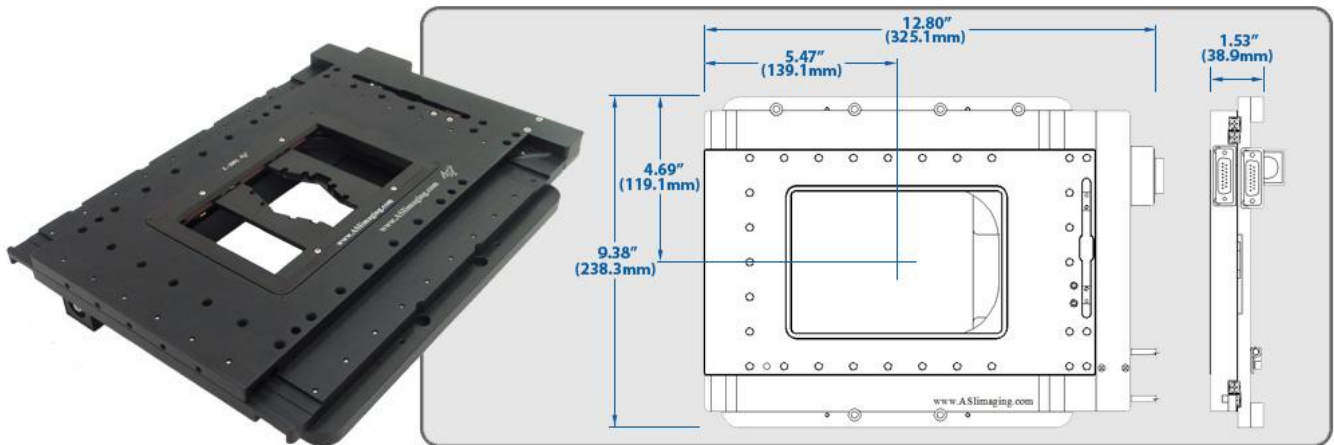

The MS-2000 Flat Top XY stage has been specifically designed to provide a high resolution, and highly repeatable, means of controlling the X, Y position of the microscope stage. The stage can be used in conjunction with ASI's proven line of Z-axis motor drives, each custom fitted to the microscope, for complete X, Y, and Z positioning. All axes derive their precise control through the use of closed-loop DC servomotors employing high-resolution rotary encoders for positioning feedback. By using closed-loop control of the stage position, there is no chance that the stage will become lost, as can occur with open-loop micro-stepped stages after a number of moves and direction changes. The MS-2000 XY stage utilizes crossed-roller slides, a high-precision lead screw, and zero-backlash miniature geared DC servomotors for smooth and accurate motion. The microprocessor-controlled MS-2000 control unit provides for RS-232 and USB communication with a host computer.

Features

- Closed-loop DC servo control of the X, Y, and Z-axes for precise positioning and highly repeatable focusing
- Wide dynamic speed range with XY joystick control
- Utilizes ASI's proven Z-axis drives
- Z-axis clutch for easy switching between manual and motor-driven focus control
- Backlit LCD display shows X, Y, and Z coordinates
- "Zero" and "Home" button for simple stand-alone operations
- Compact ergonomic tabletop control unit size is 6"D x 9"W x 3"H (9 x 23 16½ cm)
- Microprocessor control with RS-232 serial and USB communications
- Proven operation with many popular software packages

We Create Solutions

Applied Scientific Instrumentation, Inc. ♦ 29391 W Enid Rd ♦ Eugene, OR USA 97402-9533
 (541) 461-8181 ♦ (800) 706-2284 ♦ info@ASImaging.com ♦ www.ASImaging.com

Specifications for Standard Configuration (with 6.35 mm pitch Lead Screws)

XY axis range of travel	114 mm x 75 mm
XY axis resolution (encoder step)	22 nm
XY axis RMS repeatability	< 700 nm
XY axis maximum velocity	7 mm/sec
Z axis resolution (encoder step)	50 nm
Z axis repeatability	± 100 nm
Z axis maximum velocity	0.6 mm/sec
Max Recommended Load (*higher loads available upon request)	10kg

MS-2000 Options

- X, Y, and Z-axis Linear Encoders for high-accuracy positioning and focus control
- Larger stage top plate for attachment of micromanipulators, microinjectors, etc.
- Stage Wings for even more room for attachments
- Auto-Focus for stages with ASI Z-axis drives (requires NTSC, PAL, or S-Video analog signal)
- Other lead screw pitches are available

Lead Screw Options

Lead Screw Pitch Options	Rotary Encoder Resolution	Maximum Speed
25.40 mm (Ultra-coarse)	88 nm	28 mm/sec
12.70 mm (Super-coarse)	44 nm	14 mm/sec
6.35 mm (Standard)	22 nm	7 mm/sec
1.59 mm (Fine)	5.5 nm	1.75 mm/sec
0.635 mm (Extra-fine)	2.2 nm	0.7 mm/sec

- Standard Lead Screw Accuracy is 0.25 µm/mm.

Linear Encoder Options

Axis	Resolution	Scale Accuracy
XY	10 nm	± 3 µm per length of scale
Z (12 mm and 25 mm stroke)	50 nm	0.025 µm per mm

We Create Solutions

Applied Scientific Instrumentation, Inc. ♦ 29391 W Enid Rd ♦ Eugene, OR USA 97402-9533
 (541) 461-8181 ♦ (800) 706-2284 ♦ info@ASImaging.com ♦ www.ASImaging.com