

FTP-2000 Focusing Translation Platform

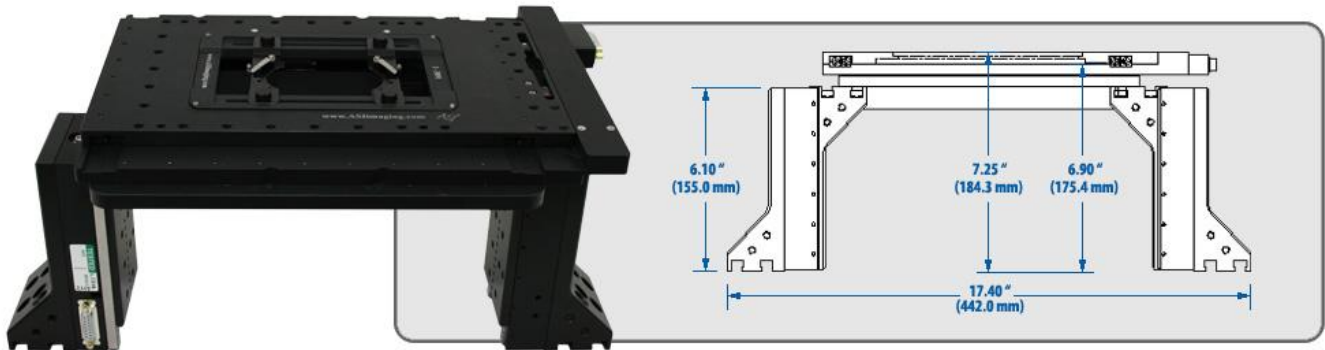

The FTP-2000 Focusing Translation Platform has been specifically designed to provide a high resolution, and highly repeatable, means of controlling the X, Y and Z position of the stage. The unit is ideal for use with fixed stage microscopes, or any application where ultra precise XYZ positioning is required. All axes derive their precise control through the use of closed-loop DC servomotors employing high-resolution rotary encoders for positioning feedback. By using closed-loop control of the stage position, there is no chance that the stage will become lost, as can occur with open-loop micro-stepped stages after a number of moves and direction changes. The FTP-2000 stage utilizes crossed-roller slides, a high-precision lead screw, and zero-backlash miniature geared DC servomotors for smooth and accurate motion. The microprocessor-controlled MS-2000 control unit provides for RS-232 and USB communication with a host computer.

Features

- Closed-loop DC servo control of the X, Y, and Z-axes for precise positioning and highly repeatable focusing
- Wide dynamic speed range with XY joystick control
- Utilizes ASI's proven LS series linear positioners for Z axis control
- Z-axis clutch for easy switching between manual and motor-driven focus control
- Backlit LCD display shows X, Y, and Z coordinates
- "Zero" and "Home" button for simple stand-alone operations
- Compact ergonomic tabletop control unit size is 6"D x 9"W x 3"H (9 x 23 16½ cm)
- Microprocessor control with RS-232 serial and USB communications
- Proven operation with many popular software packages

We Create Solutions

Applied Scientific Instrumentation, Inc. ♦ 29391 W Enid Rd ♦ Eugene, OR USA 97402-9533
(541) 461-8181 ♦ (800) 706-2284 ♦ info@ASImaging.com ♦ www.ASImaging.com

Specifications for Standard Configuration (with 6.35 mm pitch Lead Screws)

XY axis range of travel (*other travel ranges available)	120 mm x 75 mm
XY axis resolution (encoder step)	22 nm
XY axis RMS repeatability	< 700 nm
XY axis maximum velocity (*dependent on lead screw pitch option)	7 mm/sec
Z axis resolution (encoder step)	50 nm
Z axis repeatability	± 50 nm
Z axis maximum velocity (*with recommended lead screw)	1.6 mm/sec
Max Recommended Load (*higher loads available upon request)	5kg

FTP-2000 Options

- Piezo Top Plates with Z ranges of 150, 300, & 500 nm
- X, Y, and Z-axis Linear Encoders for high-accuracy positioning and focus control
- Larger stage top plate for attachment of micromanipulators, microinjectors, etc.
- Stage Wings for even more room for attachments
- Auto-Focus for stages with ASI Z-axis drives (requires NTSC, PAL, or S-Video analog signal)
- Other lead screw pitches are available

Lead Screw Options

Lead Screw Pitch Options	Rotary Encoder Resolution	Maximum Speed
25.40 mm (Ultra-coarse)	88 nm	28 mm/sec
12.70 mm (Super-coarse)	44 nm	14 mm/sec
6.35 mm (Standard)	22 nm	7 mm/sec
1.59 mm (Fine)	5.5 nm	1.75 mm/sec
0.635 mm (Extra-fine)	2.2 nm	0.7 mm/sec

- Standard Lead Screw Accuracy is 0.25 µm/mm.

Linear Encoder Options

Axis	Resolution	Scale Accuracy
XY	10 nm	± 3 µm per length of scale
Z (12 mm and 25 mm stroke)	50 nm	0.025 µm per mm

We Create Solutions

Applied Scientific Instrumentation, Inc. ♦ 29391 W Enid Rd ♦ Eugene, OR USA 97402-9533
 (541) 461-8181 ♦ (800) 706-2284 ♦ info@ASImaging.com ♦ www.ASImaging.com